

Slatwall

Primary Customer Need:

Makes the best use of vertical space in the office environment. Slatwall panels can be stacked to create a wall of Slatwall. Provides horizontal and vertical capabilities for Details Worktools. Worktools are configurable in an infinite number of ways with Slatwall.

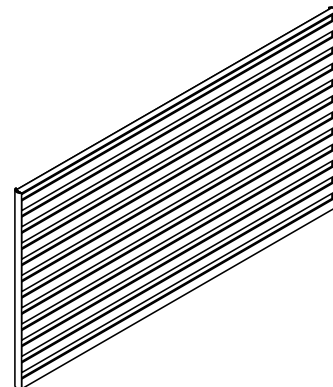

Product Features:

- Statement of Line:

Style #	Size
WS30	W30 x H12
WS36	W36 x H12
WS42	W42 x H12
WS45	W45 x H12
WS48	W48 x H12
WS60	W60 x H12

- Color: Black Slatwall is available with Black end caps
Champagne or Pewter Slatwall is available with Frost end caps
- Construction: Slatwall is extruded aluminum with plastic end caps
- Application: Panel-mounted, Wall-mounted, Context® mounted, or Freestanding
- Warranty: 10 years
- Mounts to most competitive panel systems via brackets that fit into channel of panel.
- May be wall-mounted to studs for open plan or home offices.
- Easy to field-install.
- Slatwall can be specified as an assembly (universal mounting brackets included).
Specify a "U" suffix for proper application.
- Slatwall is not dedicated to the exact panel width. 12" overhang is acceptable for tiles up to 48" wide, and 15" overhang for 60" wide.
- Slatwall can hold a maximum of 60 lbs.
- Total dimensions of Worktools specified should not exceed Slatwall dimensions.
- Brackets for competitive systems should be ordered separately.
- Product does not allow two Slatwall tiles to work in a corner application.
- End cap may be removed for applications that require two Slatwall tiles to be next to each other, or for a single Slatwall tile to fit better in a corner.

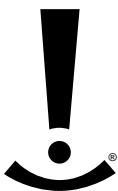

For a better day at work.™

details®

A STEELCASE COMPANY

www.details-worktools.com
P.O. Box 1967 Grand Rapids, MI 49501-1967
All rights reserved. Printed in U.S.A. 1/05