

Stella Mechanism

Customer Needs:

A readily adjustable keyboard support mechanism that is easy to operate, will work with a wide variety of support platforms and provide exceptional stability.

User Requirements:

- A simple-to-use keyboard support mechanism which provides superior stability.
- Must be applicable to any furniture system and a wide variety of workstation settings.
- Must be Cradle to Cradle Certified.

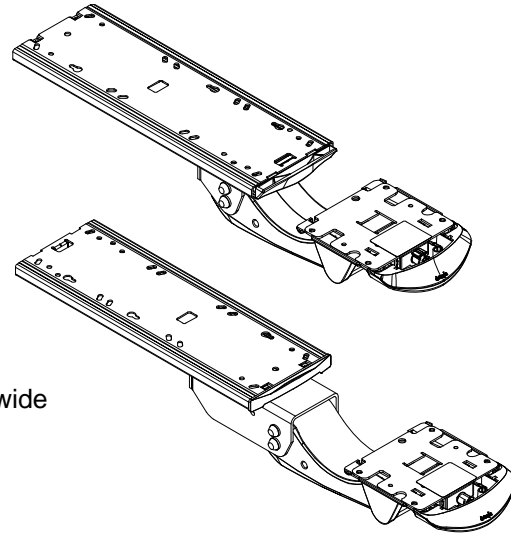

Product Features

- Style Numbers:
 - SS 20 – Standard
 - SE 23 – Extended
- Sizes:
 - Standard: W6-1/2" x H6" x D20"
 - Extended: W6-1/2" x H6-1/2" x D23"
- Weights:
 - Standard: 12 lbs.
 - Extended: 16 lbs.
- Standard requires a minimum 19-1/4" kneespace. Extended requires a minimum 23-1/2" kneespace.
- Color: Black
- Construction: Arm is cast aluminum. Track is steel.
- Application: Use in straight or corner workstation configurations with all Details platforms.
- Warranty: 10 years.
- Ideal for intensive computer user or multi-user workstation.
- Cable-controlled mechanism provides patented, knob-free adjustability.
- Applicable to either wood or metal surfaces.
- Height is activated by tilting the support platform rearward approx. 3", positioning the unit at the desired height and releasing. The unit will stay at the desired height until repositioned.
- Degrees of tilt angle possible: Between +/-15 degrees. Tilt is activated by pressing button located on underside of the tray center.
- Tilt angle is remembered by mechanism after each height adjustment.
- Product meets or exceeds all applicable ANSI/BIFMA test standards.
- Product is Cradle to Cradle Certified.

For additional information, visit the Details website: www.details-worktools.com or call 800-833-0411

For a better day at work.™

details®

A STEELCASE COMPANY

P.O. Box 1967 / CD-5E / Grand Rapids, MI 49501-1967

©2009 Office Details Inc. All Rights Reserved. Printed in U.S.A. 06/07

Subject to change without notice